

Broadband Replaces Private Circuits for Radio

Background

Operation of a remote VHF radio repeater located on a hill top location was achieved by rented private circuit from the company's offices some 6 miles away. However, when the company relocated 8 miles to the South the cost quoted for the new landline was very high. The site was also now out of reach by fallback RF link so a new connection was required.

Issues

The connection must support speech and keying signals for the remote radio which can happen instantly, so dial up lines are not suitable.

The quality of the speech must not be degraded as radio signals are sometimes poor to begin with. The cost is a major issue as the circuit is in full time use.

The radio equipment should not require modification as this would result in additional expense and more down time.



System Requirements

- To provide a low cost, point to point link
- The link to carry voice and radio keying signals
- The set up delay to be negligible, unnoticed to the user
- The quality to be maintained
- The existing radio and dispatcher to be retained

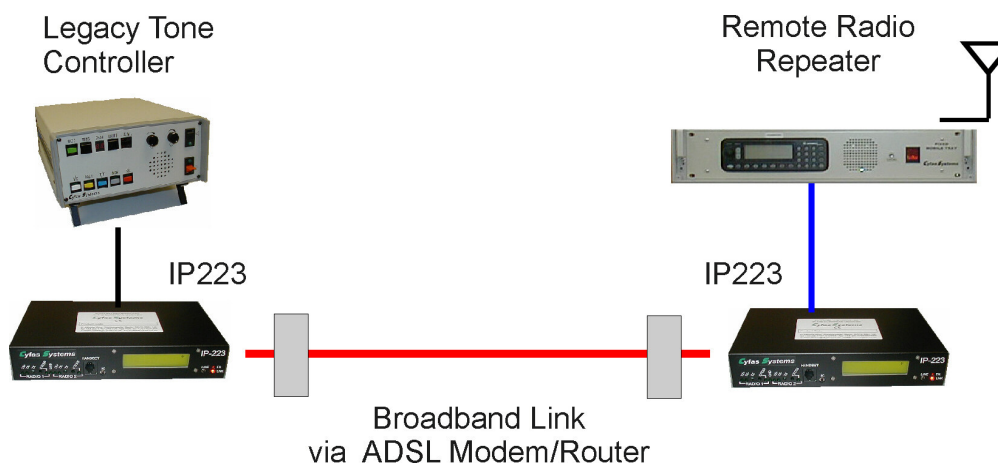

Dial up telephone lines existed at both locations which were unsuitable for the link due to the dial up time. However, for a reasonable cost they could be converted to ADSL Broadband with a 1 Mbit/second download speed, this being the entry level service for many ISP's.

Several tests were done before choosing the ISP for the project. Each line was fitted with a Netgear ADSL modem / router to establish a TCP/IP link between the sites. At each site, an IP223 VoIP radio interface was used. The remote radio site IP223 unit being set up as a standard radio interface with tone keying into the existing radio.

The local IP223 unit was set up in console mode to accept tone keying from the legacy dispatcher.

The legacy dispatcher controls the remote radio as before, but the outgoing speech and tones are captured by the IP223 where speech is encoded for voice over IP and the tones are decoded and sent as radio command messages.

At the far end the reverse happens and the radio is keyed and speech transmitted.

Findings

Preliminary test show that using the same ISP at each end worked very well as did using two different ISPs on ADSL.

Poor results were had using cable modem ISP to ADSL telephone line IP's.

Once set up with the same ISP, however, the system performed faultlessly and no difference in quality or speed of operation was noticed, even though the Broadband link introduces some 150 Milliseconds delay.

The Broadband link rental costs is about 10% of the private circuit and the IP223 equipment costs will pay back in the first year of operation.

Future

The legacy controller will soon be replaced by a fully VoIP based unit, the IP2002 which will plug right into the LAN to give multiple channels and allow unlimited controllers to share the radio.

